

INSTALLATION AND OPERATING MANUAL



PLATFORMS WITH LOW PROFILE LP SERIES and PALLET - WEIGHING PW SERIES



3000e + 3000e



INDEX

IMPORTANT WARNINGS	3
1. INTRODUCTION	4
1.1 TECHNICAL SPECIFICATIONS	4
2. INSTALLATION ON THE FLOOR	5
2.1 UNPACKING THE PRODUCT	5
2.2 INSTALLATION AND CONNECTION	5
3. INSTALLING THE CSP COLUMN	6
4. MAINTENANCE AND REPAIRS	8
4.1 TO OBTAIN THE BEST PERFORMANCE	8
4.2 BREAKDOWNS AND OVERLOADS	8
5 TRANSPORTATION OF THE PLATFORM	8
6. DRAWINGS AND CONNECTION DIAGRAMS	9
6.1 TABLE OF LP SERIES PLATFORM	9
6.2 TABLE OF PW SERIES PLATFORM	10
6.3 LP PLATFORM – FLOOR INSTALLATION	11
6.4 PW PLATFORM – FLOOR INSTALLATION	12
7. INSTRUCTIONS FOR EQUALIZING THE LP PLATFORMS	13
8. SHIELDED CABLE FOR CONNECTION OF JUNCTION BOX (JBOX) TO THE INDICATOR	14
DECLARATION OF CONFORMITY	15
WARRANTY	15



IMPORTANT WARNINGS



Make sure the following conditions are met:

- *Flat, level, stable support surface isolated from vibrations, dust, and corrosive vapours.*
- *Moderate temperature and humidity (15-30°C and 40-70%). No large air draughts.*
- *Main power supply restricted to within + 10% ÷ - 15% of the rated voltage.*
- *Adjust the feet of the platform until the air bubble level is centred*
- *Temperature and humidity moderated (do not expose to direct light of the sun, or near a source of heat)*
- *floor hardness of at least 100 kg/cm²*

Do not weld, perforate or modify the structure without consulting the reseller. If it is damaged or tampered with the warranty conditions will be annulled.

If the place of use is a humid or wet environment, the installation **must** be carried out in such a way so that water stagnation and/or scraps under the structure are **avoided**.

The platform must be connected to a weigh indicator using the fitted cable, following the indicator's instructions.

Do not step, crush or expose to sunlight the connecting screen cable.

YOU NEED TO GROUND the metallic structure of the platform using the appropriate plug, which has this symbol , especially if you need to weigh materials that, while handled, can cause **electrical discharges** (dust, plastic materials, etc.). If there are any doubts, consult the reseller.

DO NOT INSTALL IN HAZARDOUS ENVIRONMENTS.

(unless specifically made for this use)

Do not use solvents when cleaning.

1. INTRODUCTION

All **ISOLOAD** series weighing modules are built with high quality materials and are calibrated in such a way which guarantees full reliability and weighing accuracy that will last in time. The measuring elements are 4 load cells, produced in conformance to the OIML R60 standards.

The LP platforms have equalised load cells, connected to each other through an IP67 junction box IP67 fitted with a 6-pole shielded cable 5 meters long used for the connection to the weight indicator.

Every **ISOLOAD** weighing module is built and engineered to guarantee a uniform detection of the load on the load cell weighing modules, even in adverse environment conditions.

Low profile platforms suitable for weighing trolleys, pallet trucks with a weight capacity ranging from 600 kg to 1500 kg, they also permit a wide range of applications (see TABLE OF LP PLATFORM VERSIONS in page 8).

The **pallet-weighing** modules of PW series are studied for industrial and commercial applications, in which it's necessary to quickly weigh goods on pallet trucks or lift trucks with a weight capacity ranging from 600 kg to 1500 kg, they also permit a wide range of applications (see TABLE OF LP PLATFORM VERSIONS in page 9).

The platforms are built to perform efficiently in any type of environment. They are protected from a STATIC overload of over 200% of the nominal platform capacity.

The LP and PW platforms can be of two types

NORMAL

Moulded sheet-steel structure and loading surface, oven fire painted light blue RAL 5007. The measuring element consists of four shear-beam IP68 stainless steel direct load cells which are also OIML R60 approved.

STAINLESS STEEL

Structure and loading top in AISI304 stainless steel. The measuring element consists of four IP68 stainless steel load cells which are also OIML R60 approved.

1.1 TECHNICAL SPECIFICATIONS

Load cells	SHEAR BEAM
Max power supply tension tolerated	15 VDC
Nominal output (nickel-plated steel cell)	2 or 3 mV/V +/- 0,25% (depending on the model)
Combined error	< 0,03 % FSO
Compensated Temperature Range	-10°C / +40°C
Operating Temperature Range	-18°C / +65°C
Cell Resistance	
Input	350 Ohm *
Output	350 Ohm *

* or 1000 Ohm according to the models

2. INSTALLATION ON THE FLOOR

NOTE: The weighing module must be connected to its appropriate weight indicator with the cable coming from the junction box.

The indicator, connected to the platforms, can not be calibrated if not powered.

It is the customer's responsibility to prepare and calibrate the indicator.

If the platform is supplied with the indicator, the calibration is not necessary.

2.1 UNPACKING THE PRODUCT

- a) Unpack the product.
- b) Check if any damage was caused by the transportation and make sure that there are:
1 base, 4 adjustable feet, 1 junction box, 1 connection cable and 1 installation manual.

2.2 INSTALLATION AND CONNECTION

⚠ MAKE SURE TO FOLLOW THE WARNINGS ON PAGE 2. ⚠

Refer to drawing 2 and 3 when positioning the platform on the floor.

Follow this procedure when positioning the platform:

- a) Screw completely the feet (1) on the cells (2) by lifting the side of the platform. NEVER UNLOOSE THE BOLTS (3).

- b) **Level the platform** by adjusting the adjustable feet (1) until the bubble (6) is in the centre of the level. The stability of the platform is very important.

All the corners MUST REST IN A UNIFORM WAY. Carefully check that all feet fully rest on the ground and that the platform, loaded on the corner, is not unstable (if a corner is not resting on the ground its relative foot is easier to turn).

Furthermore, in order to maintain the platform performance, the feet must be adjusted in order that the height (LP Platform, H and PW Platform, C) of the platform corresponds to that shown in the table in page 10 and 11.

In no circumstance, the limits shown in the drawing below must be exceeded.

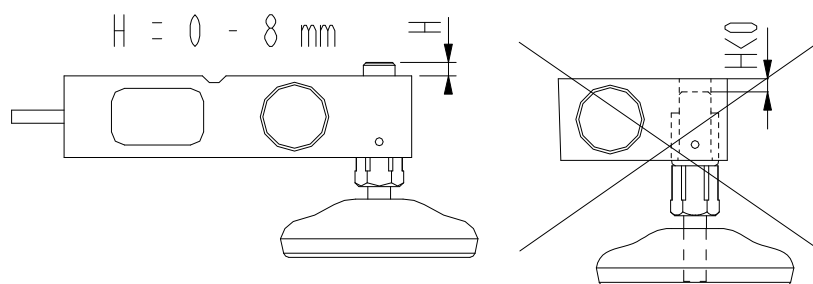

- c) Open the trapdoor (the platform LP, 5 fig.2) (the platform LP, 5 fig.3) by removing its screws, and connect the screened cable, connected to the junction box, at the instrument. The cable must be free, so that the resistances are not energised, which could alter the measurement. Refer to chapter 8 for cables colour and function.
- d) Reposition the trapdoor (5 fig.2 and 5 fig.3) on the loading top using its screws.

PLATFORM

- a) If the platform and the indicator are supplied together, the calibration is not necessary, go to chapter 4.
If platform and indicator are not supplied together, follow the specific instructions of the indicator to make the scale operate and then follow the instructions in step b), c), d) and e).
- b) The calibration should be done 15 minutes after the indicator has been turned on.
- c) Calibrate the indicator following the instructions on its technical manual.
- d) Check the corners (see the ET PLATFORM EQUALIZING, chapter 7) of the platform by positioning on these (one at a time) a weight equal to $\frac{1}{3}$ of the indicator's maximum capacity. Check that the error is not greater than $+ / - 2$ divisions and if this is not the case, contact the RESELLER.
- e) Using a reference weight, check the zero and the full-scale capacity.

3. INSTALLING THE CSP COLUMN

(See FIGURE 1)

1. Lock column (B) to base (G) with two screw 10x30 (H).
2. Screw nut (L) on feet (I).
3. Screw the four feet (I) to the base (G).
4. Make the connecting cable, coming from the scale, go through hole (C) of base (G) and run it inside column (B) until you get it out from hole (A).
5. Make now the cable (coming out from hole A) go through the cable plug (lower right side of indicator D) and inside the indicator, connect the cable to the terminal board (refer to the indicator manual).
6. Set the weigh indicator (D) to column (B) with two screw 6x20 (E) and with washer diameter 6 (F). Make sure the cable, connecting the scale, is stretched.
7. Set the column CSP perpendicular to the floor, by adjusting feet (I).
8. Tighten the M10 nuts (L).

FIGURE 1

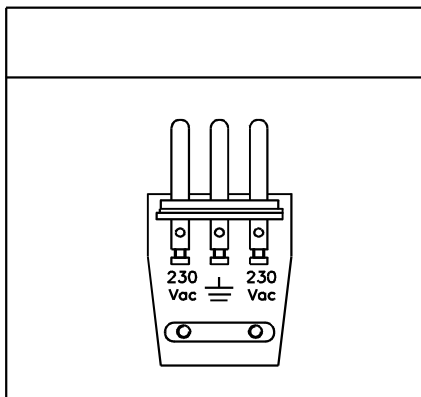
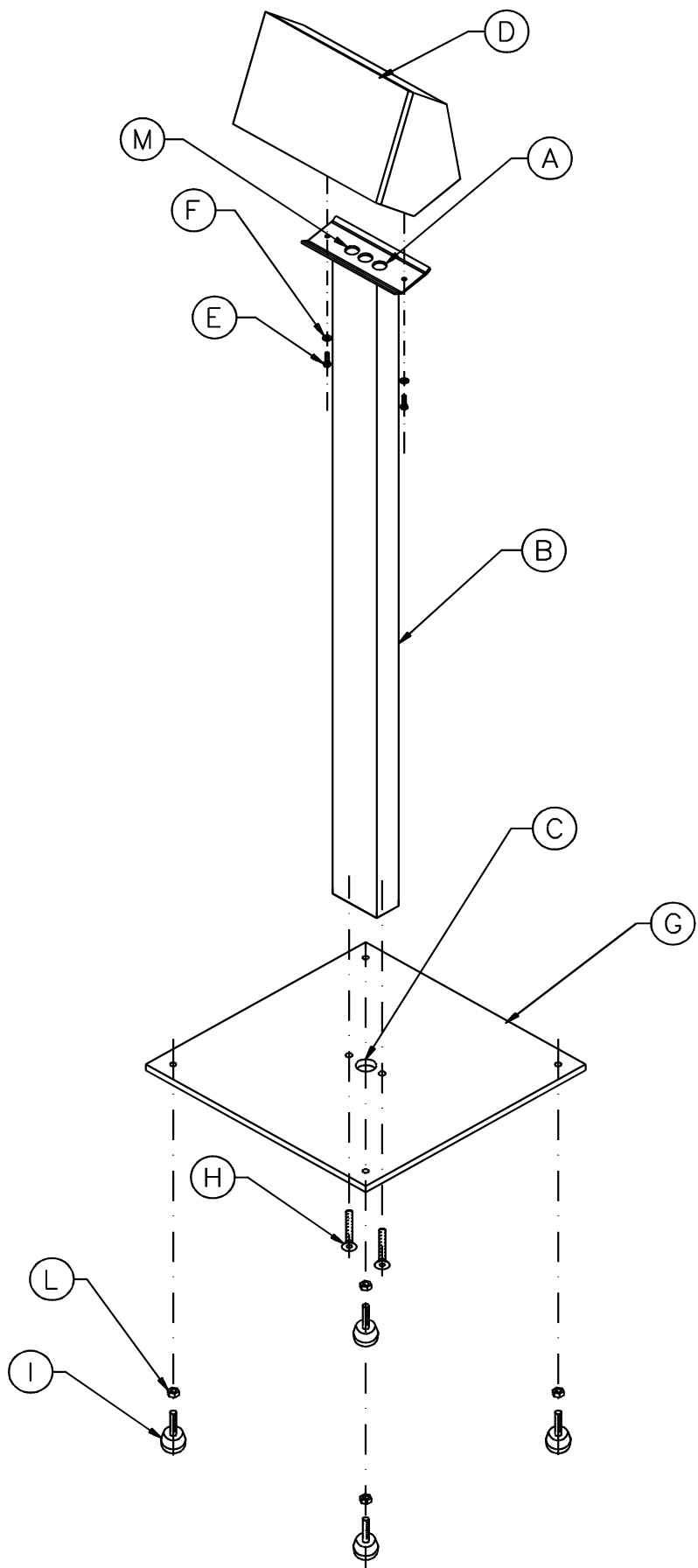

BLUE	GREEN YELLOW	BROWN
230 Vac	⊕	230 Vac

4. MAINTENANCE AND REPAIRS

4.1 TO OBTAIN THE BEST PERFORMANCE

- One should keep the platform clean. If dirt and dust accumulate on the platform one should clean it with a damp cloth or with the common cleaning products (**do not use SOLVENTS and ACIDS**)
- Avoid platform collisions because this could cause serious damages.

4.2 BREAKDOWNS AND OVERLOADS

If you think the platform is broken or damaged disconnect it in a permanent way. Do this if the platform:

- appears to be damaged
- does not work
- has been loaded more than its tolerable limits (which could happen during the transportation or at time of storage)

5 TRANSPORTATION OF THE PLATFORM

To pack the platform follow the procedure below:

- a) turn off the indicator
- b) disconnect the platform's indicator
- c) remove the feet
- d) for the pallet weighing: put the wooden wedges under the cells and fix the straps.

6. DRAWINGS AND CONNECTION DIAGRAMS

6.1 TABLE OF LP SERIES PLATFORM

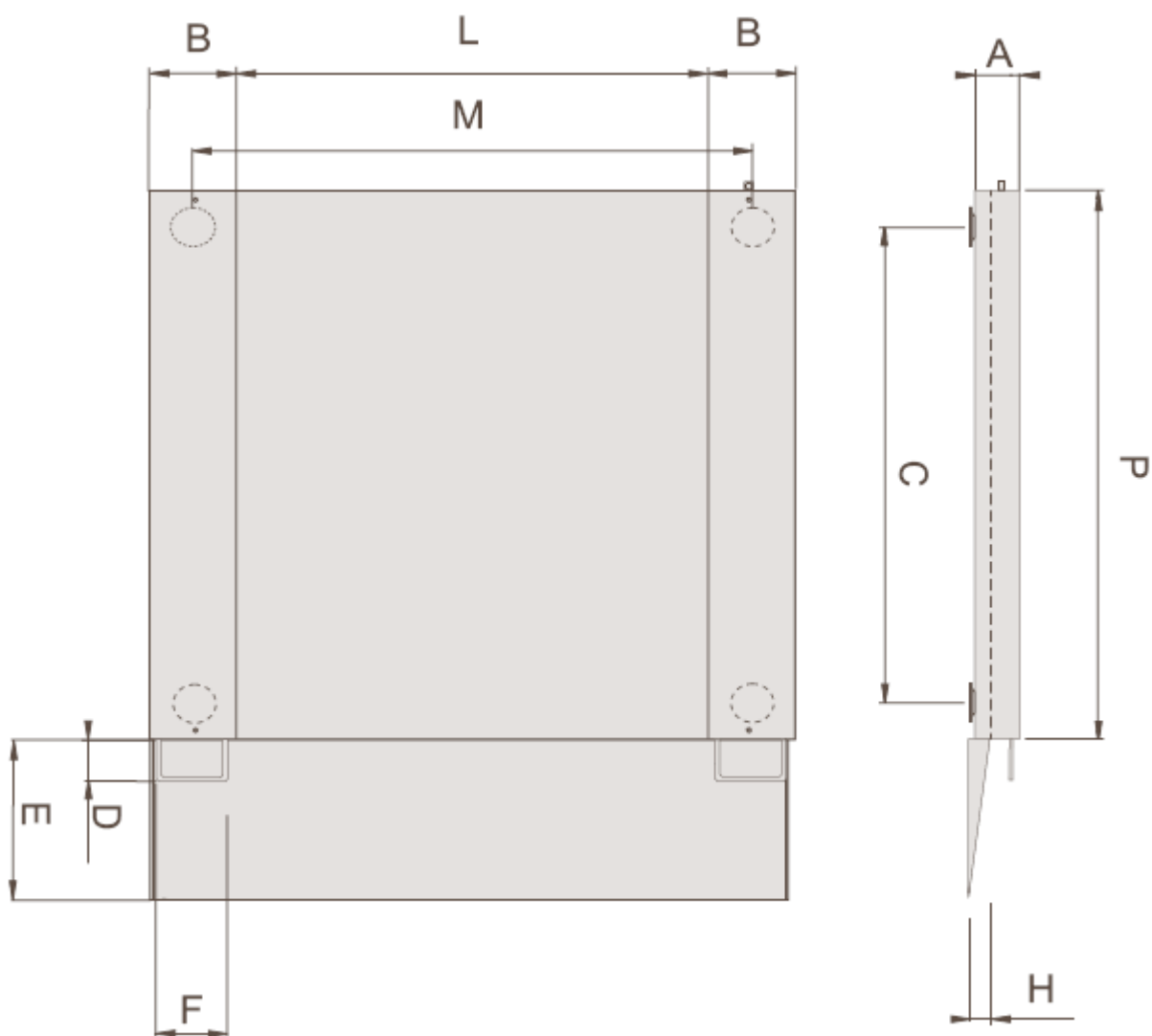

PLAFTORM MODEL	DIMENSIONS mm									
	L	P	H	A	B	C	D	E	F	M
LPE6 / LPEI6	1000	1250	45	90	125	1070	60	350	110	1130
LPE15 / LPEI15	1000	1250	45	90	125	1070	60	350	110	1130
LPF6 / LPFI6	1250	1500	45	90	125	1380	60	350	110	1380
LPF15 / LPFI15	1250	1500	45	90	125	1380	60	350	110	1380

6.2 TABLE OF PW SERIES PLATFORM

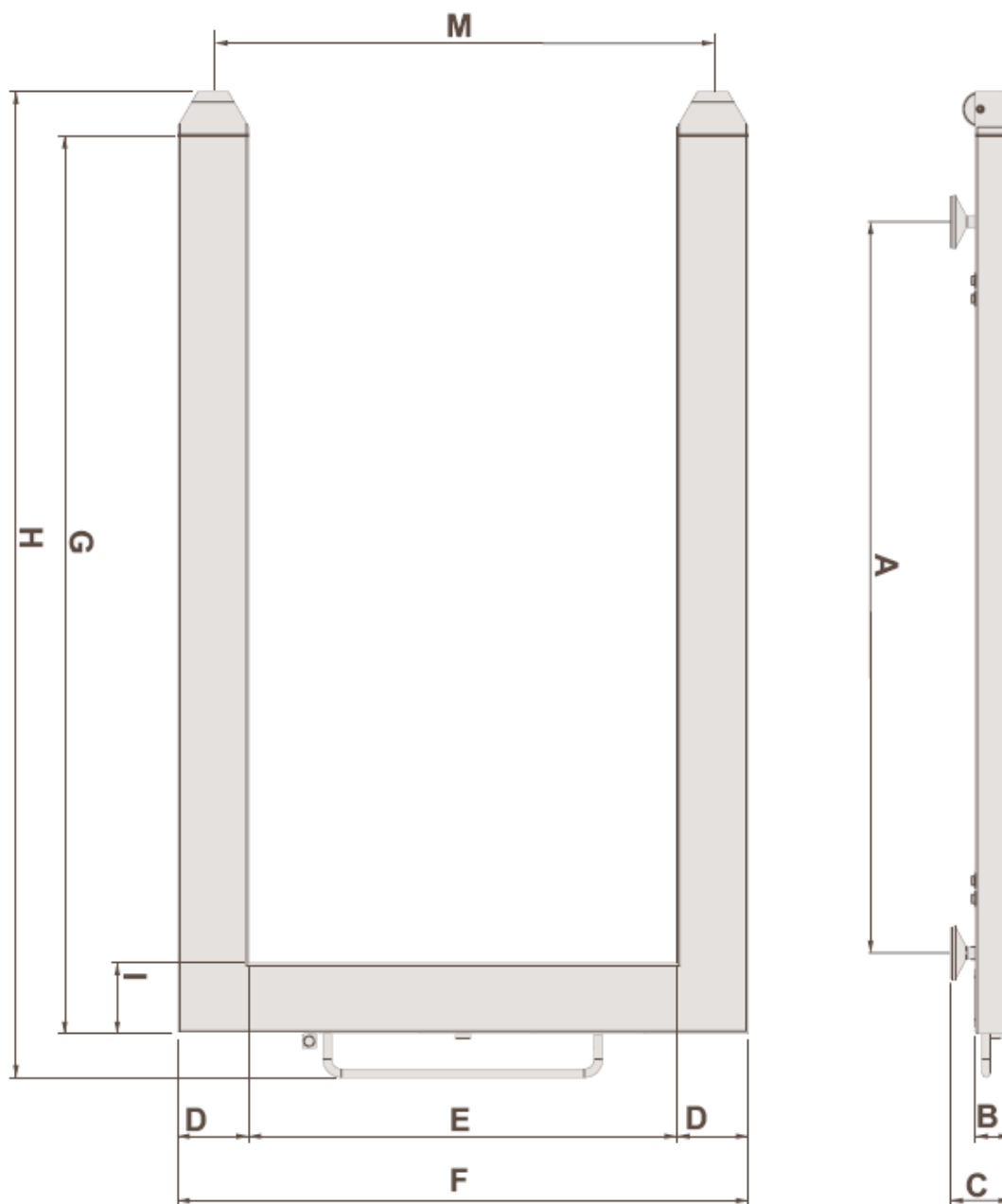

PLATFORM MODEL	DIMENSIONS mm									
	A	B	C	D	E	F	G	H	I	M
PW6	1020	70	85	110	600	820	1260	1385	120	710
PW15	1020	70	85	110	600	820	1260	1385	120	710
PW30	1020	70	85	110	600	820	1260	1385	120	710

6.3 LP PLATFORM – FLOOR INSTALLATION

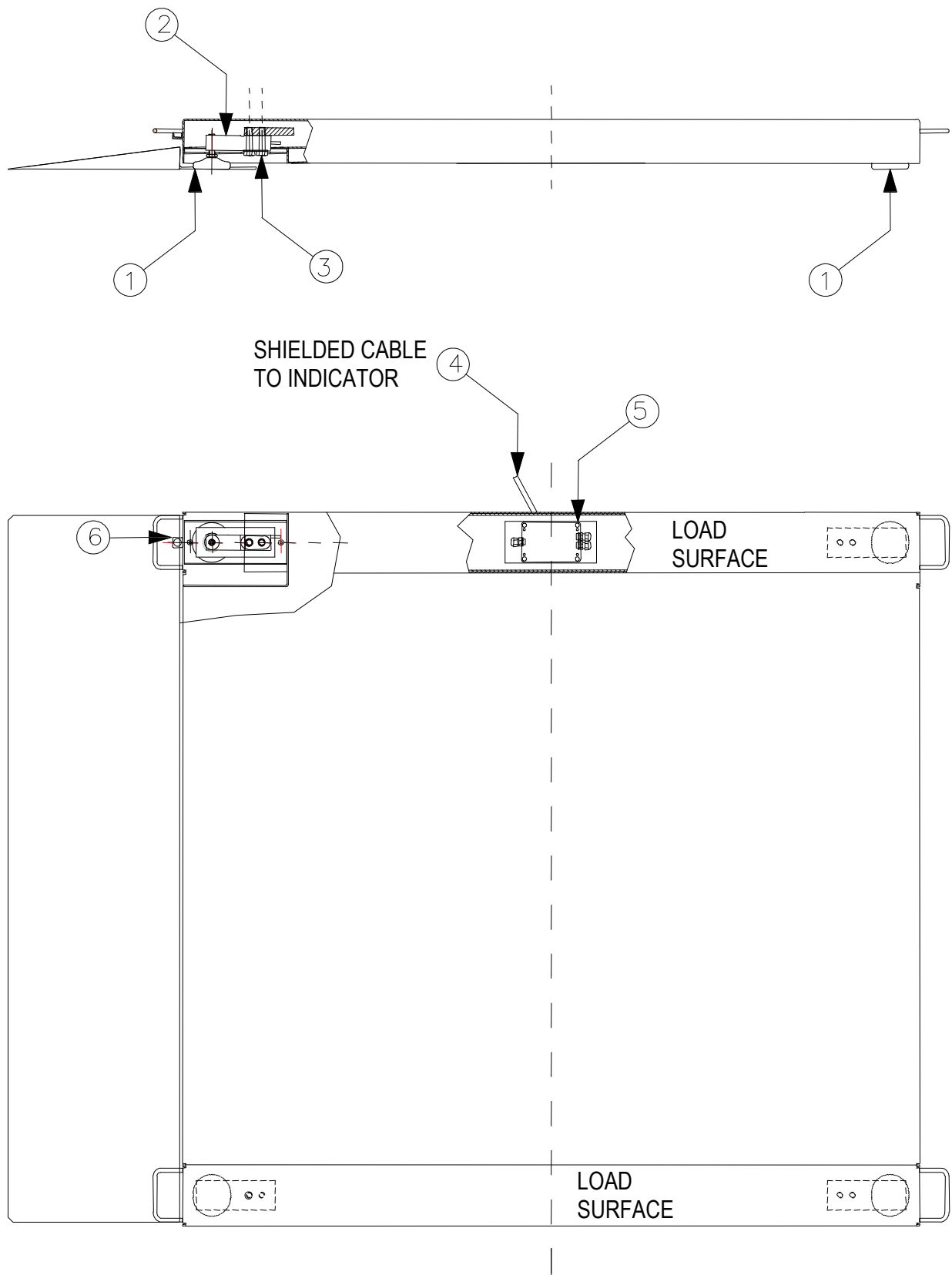

Fig.2

6.4 PW PLATFORM – FLOOR INSTALLATION

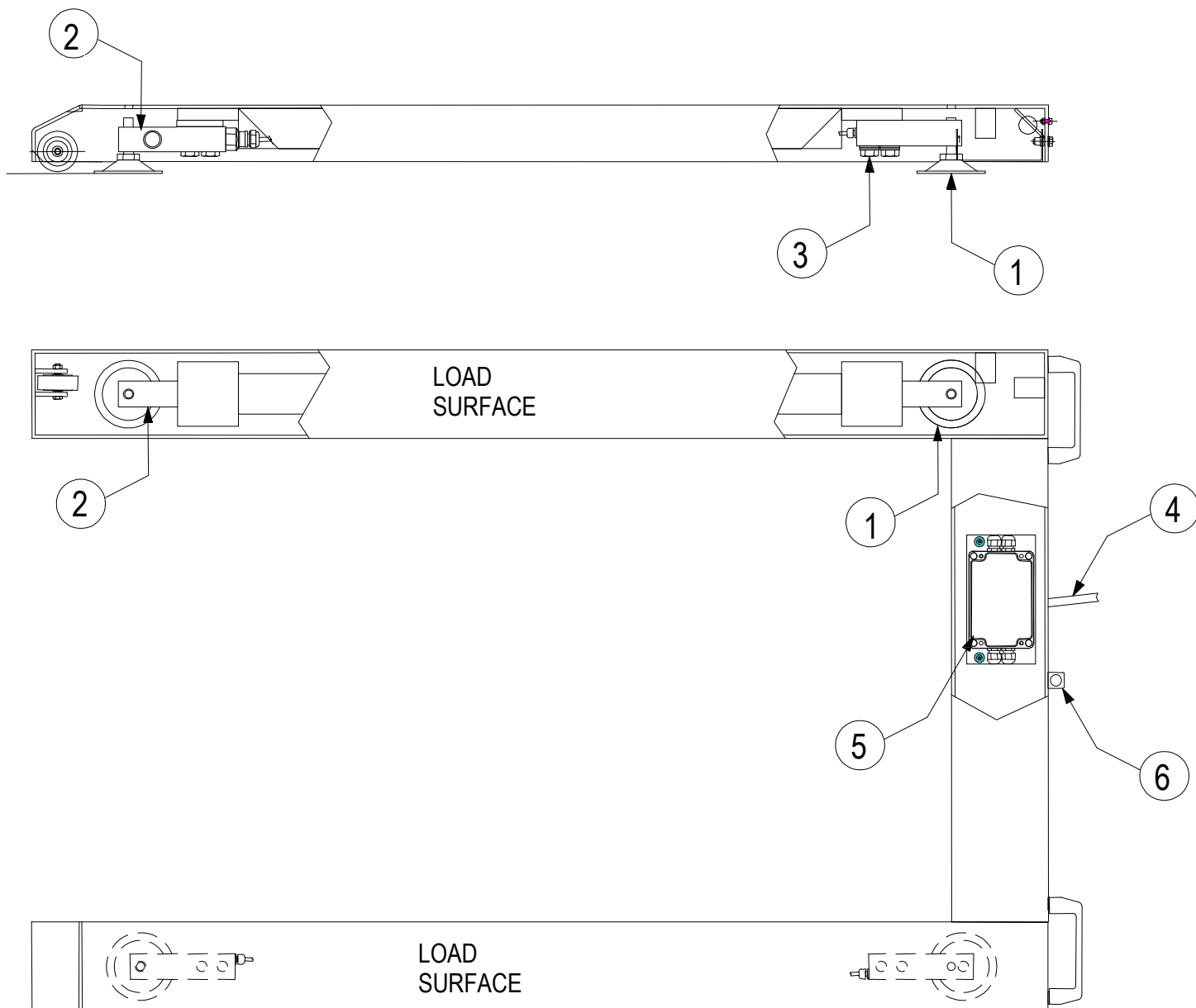
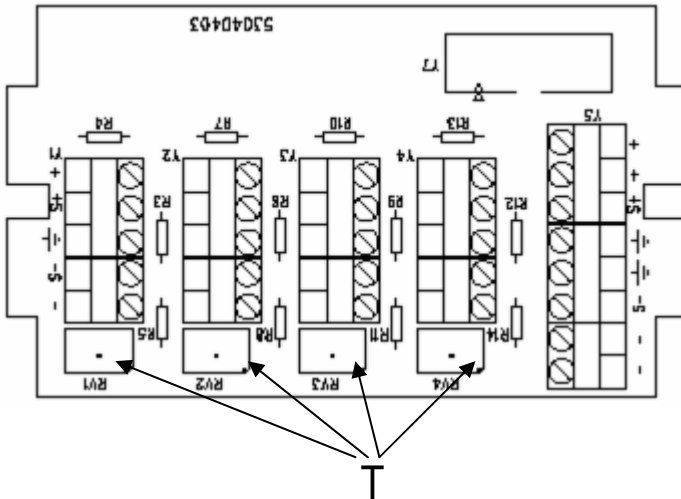

Fig.3

7. INSTRUCTIONS FOR EQUALIZING THE LP PLATFORMS

1. Make 20 turns (clockwise) of the screws of all the "T" trimmers in order to have the maximum signal on all the cells.

EQUALIZATION BOARD



2. Carry out the calibration with mass in the central point (i.e.: scale's full scale capacity).
3. Put the indicator in visualization x 10 mode.
4. Place the sample weight (about 1/3 of the capacity) alternatively on each of the four angles of the platform "1, 2, 3, 4" and identify the cell which shows the lowest weight.

LP PLATFORM CELL LAY-OUT

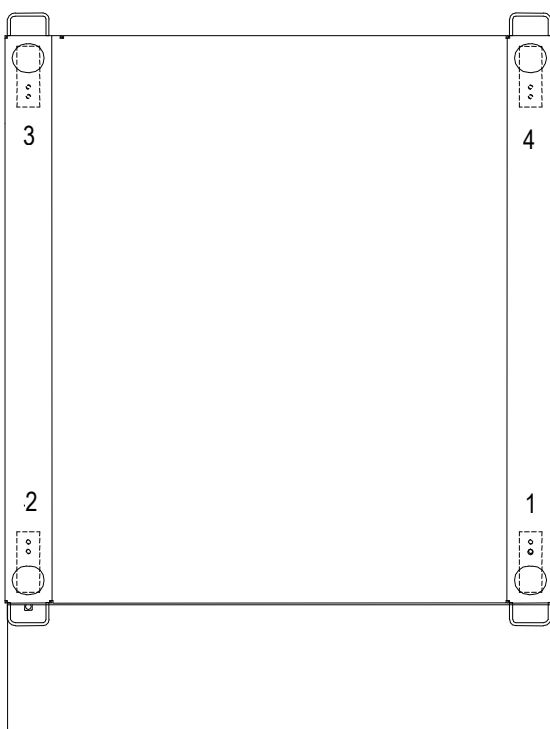

PW PLATFORM CELL LAY-OUT

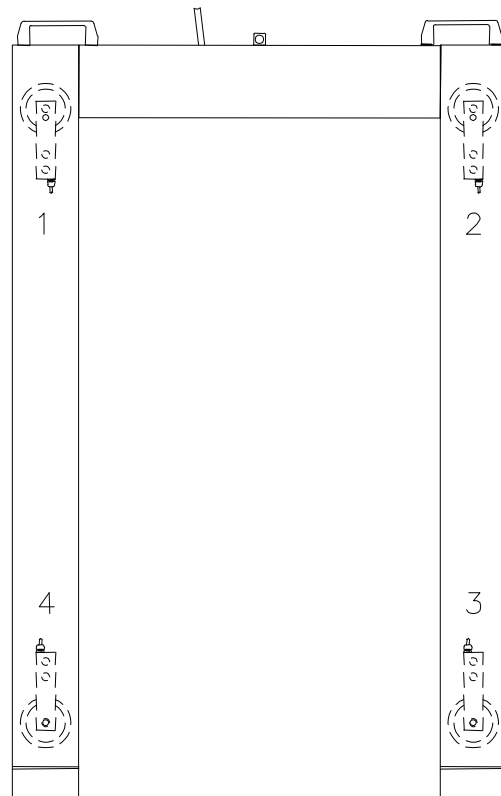

5. Adjust the trimmers of the remaining 3 cells so that all three display the same weight as the cell with the lowest weight; do as follows:
 - a. Position the sample weight on the angle corresponding to the cell with the greatest signal.
 - b. Turn (counter-clockwise) the screw of the “T” trimmer of the corresponding cell until the weight equal to that of the cell with the lowest signal is displayed.
 - c. Repeat steps “a” and “b” for the remaining two angles.
6. Check again making sure that on all four angles the same weight is displayed, otherwise adjust the trimmers of the single cells as described in points 4 and 5.
7. Once again calibrate the scale.

Notes:

- So that the equalization is carried out well, it is advisable to use a small-sized sample weight having a value which is about 1/3 of the capacity in order to concentrate the load on each single cell; the equalization can be considered satisfactory if the weights displayed differ of about 1 division.
- In weighing systems for hazardous areas, special junction boxes may be used. The equalisation described in this manual is relative to the standard junction box.

8. SHIELDED CABLE FOR CONNECTION OF JUNCTION BOX (JBOX) TO THE INDICATOR

EXCITATION +	Brown
SENSE +	Green
EXCITATION -	Grey
SENSE -	White
SIGNAL +	Pink
SIGNAL -	Yellow
EARTH BRAIDING	Orange

The cable that comes out from the indicator should be connected to the equalisation board inside the junction box.

It has 4 wires:

- Brown and Green wires, together on the same prod, connected to the + of the junction box.
- Grey and White wires, together on the same prod, connected to the – of the junction box.

In case the platform is supplied without the indicator, the end of the cable to connect to the indicator has 6 wires whose meaning is shown in the above table.

DECLARATION OF CONFORMITY

This device conforms to the essential standards and norms relative to the applicable European regulations. The Declaration of conformity is available in the web site www.diniargeo.com

WARRANTY

The TWO-YEAR warranty period begins on the day the instrument is delivered. It includes spare parts and labour for repairs at no charge if the INSTRUMENTS ARE RETURNED prepaid to the DEALER'S PLACE OF BUSINESS. Warranty covers all defects NOT attributable to the Customer (such as improper use) and NOT caused during transport.

If on site service is requested (or necessary), for any reason, where the instrument is used, the Customer will pay for all of the service technician's costs: travel time and expenses plus room and board (if any).

The customer pays for shipping costs (both ways), if the instrument is shipped to the DEALER or manufacturer for repair.

The WARRANTY is VOIDED if faults occur due to work done by unauthorised personnel or due to connections to equipment installed by others or incorrect connection to the power supply.

This warranty DOES NOT provide for any compensation for losses or damages, direct or indirect, incurred by the Customer due to complete or partial failure of instruments or systems sold, even during the warranty period.

AUTHORISED SERVICE CENTRE STAMP

